



Eurobot<sup>open</sup> 2008

Mission to Mars



---

Rules 2008

---



**Find proofs of life and bring them to Earth...**

**For analyse!**

*The robot which will bring back to Earth the most living organisms*

*in good conditions will be the winner.*



Eurobot<sup>open</sup> 2008

Mission to Mars



---

## Rules 2008

---

# 1. Scope

The rules which follow apply to all national qualifications and to the final of the Edition 2008 of the competition of autonomous robots Eurobot<sup>open</sup>.

Eurobot<sup>open</sup> is an amateur robotics contest open to teams of young people from around the world, organised in teams. These teams could be formed from students as part of their studies or as independent clubs or non-profit organizations. A team must be made up of two or more active participants. Team members may be up to 30 years old, each team may have one supervisor for which this age limit does not apply.

The aims of the contest include interesting the public in robotics and encouraging hands-on practice of science by young people. Eurobot<sup>open</sup> is intended to take place in a friendly and sporting spirit.

More than a simple championship for young people or a competition, Eurobot<sup>open</sup> is a friendly opportunity to unleash technical imagination and exchange ideas, know-how, hints and engineering knowledge around a common challenge. Creativity and interdisciplinary is necessary. Eurobot<sup>open</sup> values fair play, solidarity, creativity and sharing of technical knowledge, whether it is across technical realisations or project management.

Participating to the competition implies the acceptance of the rules and the interpretations of them, made by the refereeing committee throughout the year and by the referees during competition matches. The referees' decisions are final and may not be challenged, except of common agreement between all implicated parties .

Eurobot<sup>open</sup> takes place in Europe, but is open to teams from other continents. Countries with more than three teams interested in participating must organise a national qualification in order to select the three teams which will participate to Eurobot final. The selection will typically include the two best teams (in terms of competition score), but it is left to each national organisation committee to agree on a possible alternative to competition for selecting its last team. For example, the third team can be chosen by a jury according to other qualities valued by the contest, such as: best concept, most creative, fair-play, etc...

The qualified teams from the national cups of Algeria, Austria, Belgium, France, Germany, Great Britain, Italy, the Czech Republic, Romania, Russia, Serbia, Spain, Switzerland and of all other new national qualifications born in 2008, will meet their international counterparts (multinational teams and teams from countries without qualifications) from Wednesday, 21<sup>st</sup> till Sunday, May 25<sup>th</sup>, 2008, in the city of Heidelberg (Germany), to participate to the Eurobot<sup>open</sup> final.

Eurobot<sup>open</sup> was born in 1998, in the wake of the French Cup of Robotics, following the constitution of a similar competition in Switzerland. To deal with the expansion of the contest and to maintain the original spirit of exchange and cooperation between the different organisers, an association was founded.



Eurobot<sup>open</sup> 2008

Mission to Mars



---

## Rules 2008

---

The association, officially born in May 2004, was named Eurobot. You can find its statutes on our website ([www.eurobot.org](http://www.eurobot.org)). Individuals or organisations sharing our values are most welcome to support us either financially, or by joining us as volunteers in one of the different organising groups.

It is important to note that the most of national competitions, within the limits of their means, are opened to the foreign teams, and multinational teams are also welcome of course. Moreover, numerous teams organize their own friendly competitions.

Eurobot<sup>open</sup> and the national qualifications are prepared with passion throughout the year by persons of any nationalities, volunteers for most of them, which believe in the educational values of this experience and are themselves, often, ancient participants.

Welcome!

And have a nice adventure!



---

## Rules 2008

---

### 1.1. Contents

1. Scope.....	2
1.1. Contents.....	4
2. Basic rules.....	7
2.1. Forewords.....	7
2.2. This year theme.....	7
2.3. Refereeing.....	7
3. Playing area and element definitions.....	8
3.1. General notes.....	8
3.1.1. Tolerances.....	8
3.2. The playing area.....	8
3.3. Starting Areas.....	10
3.4. Borders.....	10
3.5. Beacon supports.....	10
3.6. Samples, ice and prospecting zones.....	10
3.6.1. Samples and ice.....	11
3.6.2. Prospecting zones.....	11
3.6.2.1. Vertical dispensers.....	11
3.6.2.2. Horizontal dispenser.....	12
3.6.3. Samples and ice distribution on the table.....	14
3.7. The containers.....	15
3.7.1. The standard container .....	15
3.7.2. The cooled containers (safe zones).....	16
4. The robots.....	17
4.1. General notes.....	17
4.1.1. Visibility.....	18
4.2. Limitations and safety issues.....	18
4.2.1. Carrying or throwing the balls.....	18
4.2.2. Usage of blowers or vacuum systems.....	18
4.2.3. Fair-play.....	18
4.2.4. Safety.....	19
4.3. Mandatory equipment.....	19
4.3.1. Starting cord.....	19
4.3.2. Emergency OFF button.....	19
4.3.3. Automatic shut down .....	20



---

## Rules 2008

---

4.3.4. Obstacle avoidance system.....	20
4.4. Robot Dimensions.....	20
4.5. Energy Sources.....	21
4.6. Control Systems.....	22
4.7. Robot localisation beacon support.....	22
4.8. Technical poster.....	23
5. Beacons.....	23
5.1. General Comments.....	23
5.2. Robot Localisation Beacon.....	24
5.3. Fixed beacons.....	25
5.4. Communication signals.....	25
6. Match time line.....	25
6.1. Robot identification.....	25
6.2. Start procedure.....	25
6.3. Match sequence.....	26
6.4. Score calculation.....	27
6.4.1. Points.....	27
6.4.2. Bonus points.....	27
6.4.3. Scratch.....	27
6.4.4. Penalties.....	28
6.4.5. Match point.....	28
6.4.6. Disqualification.....	29
7. Contest master time-line.....	29
7.1. Approval.....	29
7.1.1. Physical examination and team interview.....	29
7.1.2. Practical trials.....	29
7.1.3. Modifications after approvals.....	30
7.2. Qualification round.....	30
7.3. Final round.....	30
8. Appendices.....	32
8.1. Playing area drawing.....	32
8.2. Reflective tape.....	34
8.3. Painting references.....	35
8.4. Balls specifications.....	35



Eurobot<sup>open</sup> 2008

Mission to Mars



---

## Rules 2008

---

<u>8.5. Safety.....</u>	<u>36</u>
<u>8.5.1. On-board voltage.....</u>	<u>36</u>
<u>8.5.2. Compressed-air systems.....</u>	<u>36</u>
<u>8.5.3. Lasers.....</u>	<u>36</u>
<u>8.5.4. Powerful light.....</u>	<u>37</u>



Eurobot<sup>open</sup> 2008

Mission to Mars



---

## Rules 2008

---

## 2. Basic rules

### 2.1. Forewords

---

The following rules are applicable to the Eurobot<sup>open</sup> 2008 autonomous robot contest. All the national qualifications must conform to these rules. If your national organizing committee wishes to modify some parts of the rules, it has to be validated by the Eurobot Executive Committee. However, whatever rules are defined on a national level, teams and robots can be qualified and participate to the finale only if they respect the ones described in the present document. In addition, they must keep in mind that during Eurobot finale, only the present rules will apply.

### 2.2. This year theme

---

This year, robots are searching for proofs of life on planet Mars. The rock samples potentially containing living organisms are represented by red or blue balls. To be safely brought back to Earth, they need to be maintained at the same cold temperature as the place they were collected. So there are two kinds of containers: two *cooled containers* where the samples don't need anything else to be preserved, and a *standard container* where the samples need to be packed with ice, represented by white balls.

Only one robot per team is allowed in the match. The matches involve two teams and last 90 seconds.

Each team is associated with a colour, red or blue. Each team has a start area coloured accordingly, located at one of the back corners of the table. Exploration zones where robots can collect samples and ice are represented by vertical and horizontal balls dispensers.

Each robot has to collect some samples potentially containing living organisms, and either shoot them into the cooled container (located in height) or deposit them into the standard container. The standard container is located along the front edge of the table, each team being allocated one half of this site as its goal area. Then the robot has to go back and find more samples. Since samples deposited in the standard container must be preserved in ice, if a coloured ball figuring a sample is placed between two white balls figuring ice, the robot will score additional bonus points. Smart robots can also move, insert and/or pick up samples or ice within the standard container to improve their score!

### 2.3. Refereeing

---

Each match will be overseen by two referees. For all the matches of Eurobot final, at least one of the two referees will be from a country different from both of the competing teams.



Eurobot<sup>open</sup> 2008

Mission to Mars



---

## Rules 2008

---

The referees are intended to interpret and apply the rules during the competition and approval phase. But they are also there to help the teams, by clarifying points for instance. So you are encouraged to contact the referees with questions about the rules or the competition process.

# 3. Playing area and element definitions

## 3.1. General notes

---

A reference of parts and products used to make the game components is included in an appendix at the end of this document.

### 3.1.1. Tolerances

The organisers are committed to build the playing area to the highest degree of accuracy. But they do allow for the following fabrication tolerances:

- 2% with respect to the playing field construction,
- 5% with respect to the playing element construction,
- 10% with respect to painted markings.

No complaints related to fabrication variations within the above tolerances will be considered.

The teams are warned that the paint finish of the table may vary from one playing area to another and may degrade during the competition.

If problems with the rules are discovered, the definition of the field and game components may be modified over the course of the year. We strongly advise participating teams to regularly consult our web site <http://www.eurobot.org/> in the 'FAQ' section for potential amendments and to follow the discussion and the information on the forum [www.planete-sciences.org/forum](http://www.planete-sciences.org/forum).

**Important note:** above tolerances apply to the playing field and other components of the game only. They do not apply to robots and localisation beacons prepared by the participating teams, which are required to respect the limitations described later in this document.

## 3.2. The playing area

---

The playing field is **2100 mm wide** and **3000 mm long**, plus external areas: the cooled containers and the standard container. These areas are considered as parts of the playing area. The playing area is painted in grey yellowish.





---

## Rules 2008

---

The standard container is located along the front side of the playing field. It is made of two sloped sections, whose outer ends are in level with the table.

The cooled containers are located at the front end of the short sides of the table. They are represented by rectangular baskets.

There are 5 ball dispensers, representing the samples prospecting zones and iced area. They are placed near the start areas of the robots, along the rear and side edges of the table.

**There are four vertical ball dispensers:**

- one filled with blue balls and one filled with white balls, on the same side as the blue team starting area,
- one filled with red balls and one filled with white balls, on the same side as the red team starting area,

**There is one horizontal dispenser :**

- filled with mixed balls (blue and red), located along the rear edge of the table, half distance from both start areas. This mixed dispenser is horizontal and requires a manual action to free the balls it contains.

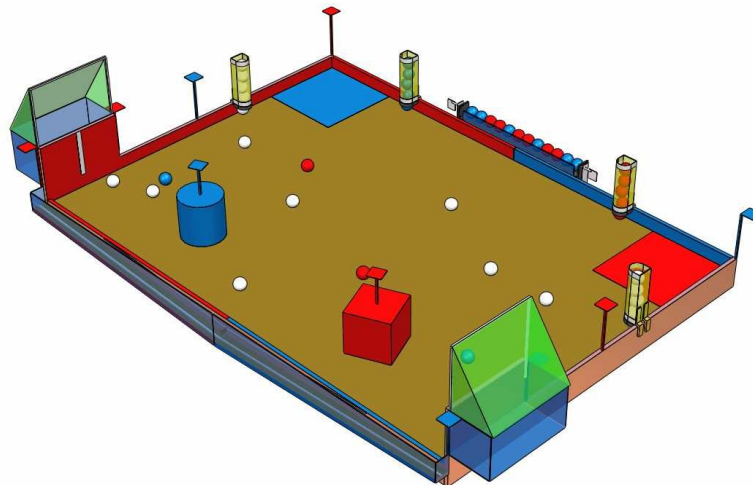



---

## Rules 2008

---

### 3.3. Starting Areas

---

The starting areas are on the rear corners of the table. Each starting area is a **500 mm square**, painted in the respective team's colour (red or blue). At the beginning of the match, robots must be placed in these areas, and **touching both borders of the table**.

### 3.4. Borders

---

The table border is **75 mm high** (above the table level) and **22 mm thick**. The border separating the standard container from the main part of the table is **20 mm high** (above the table level) and **22 mm thick**. The border in front of the cooled containers is **350 mm high** and **22 mm thick**.

Half of the rear border is painted red, on the opposite side of the red robot starting area, the rest is painted blue. Side borders are also painted using the colour of the starting area located on the opposite end of the table.

The interior (i.e. facing the robot evolution area) and top faces of the border separating the standard container from the table are painted half blue and half red to indicate each team dedicated area. The distribution of the colours uses the same logic as for other borders, hence the part allocated to a robot is the far most one from its starting area.

### 3.5. Beacon supports

---

Two beacon supports are installed at each back corners. Two other ones are in the middle of each short sides. Two beacon supports are located on each side of the cooled containers. The mast of the beacon supports are painted in black.

Each team is allowed to use four beacon supports located :

- in the middle of the short side of its starting area,
- on the back corner of the opposite side of its starting area,
- on each side of the cooled container of the opposite side of its starting area.

The beacon supports are **80 mm square** platforms placed **350 mm** above the table level. The platform is covered with Velcro (rough "hook" side).

### 3.6. Samples, ice and prospecting zones

---

There are **45 balls**, of three types: 13 blue (samples), 13 red (samples) and 19 white (ice).



---

## Rules 2008

---

### 3.6.1. Samples and ice

These playing elements are floorballs. The balls come in three colours: red for the red team, blue for the blue team, and white, for both teams. The ball diameter measures **72 mm**. Detailed specifications of these balls are provided in paragraph “*Balls specifications*” later on.

At the beginning of the match the 45 balls are distributed on the table and in the ball dispensers as follows:

- 13 balls on the table : 9 white, 2 blue and 2 red
- 20 balls are in the vertical dispensers :
  - 5 white in the dispenser located on the short side of the table near the red starting area,
  - 5 white in the dispenser located on the short side of the table near the blue starting area,
  - 5 blue in the dispenser located at the back of the table near the blue starting area,
  - 5 red in the dispenser located at the back of the table near the red starting area
- 12 balls are in the horizontal dispenser : 6 blue, 6 red

### 3.6.2. Prospecting zones

There are two kinds of prospecting zones:

- the samples prospecting zones (in the horizontal dispenser, inside the two vertical dispensers and the central part of the table)
- the frozen zone, filled with ice (in two vertical dispensers and on the table)

#### 3.6.2.1. Vertical dispensers

The vertical dispensers are designed so that when a ball is removed from their bottom, the next one (if any) will move down and take its place. Only one ball can be picked at a time.



---

## Rules 2008

---

They are built as a semi-cylinder, which back face is made of a 5 mm thick plexiglass plate, and the front face is made of a curved transparent plastic sheet. The rear plate is **300 mm high** and **85 mm wide**. The curved plastic sheet is **300 mm high** and **225 mm wide**.

Reflective tapes are stuck at the top and the bottom of the vertical dispensers, as illustrated in the drawing on the right.

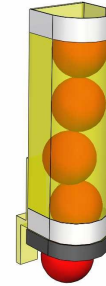

The bottom edge of the curved sheet is equipped with a soft brush, such as the ones placed at the bottom of doors (*see photo hereafter*), to keep in place the ball ready to be picked. This brush is between **20 and 22 mm high**.



The vertical dispensers situated on the side of the table are placed at 750 mm from the back corners. The vertical dispensers situated at the rear of the table are placed at 700 mm from the back corners. The dispensers are fixed to the table border by their rear plate, the bottom end (not including the brush) being located **75 mm** above the table level.

### 3.6.2.2. Horizontal dispenser

The horizontal dispenser is located in the middle of the rear border of the table, half distance from the starting areas.

Opening of this dispenser is triggered by pushing one of the buttons located on each of its ends. These activating buttons are **60x60 mm** square plates, which must be pushed at least 1cm to guarantee activation. Upon activation, the front door slides down, releasing all the balls contained in the dispenser, which will then roll out on the table.



Eurobot<sup>open</sup> 2008

Mission to Mars



---

Rules 2008

---

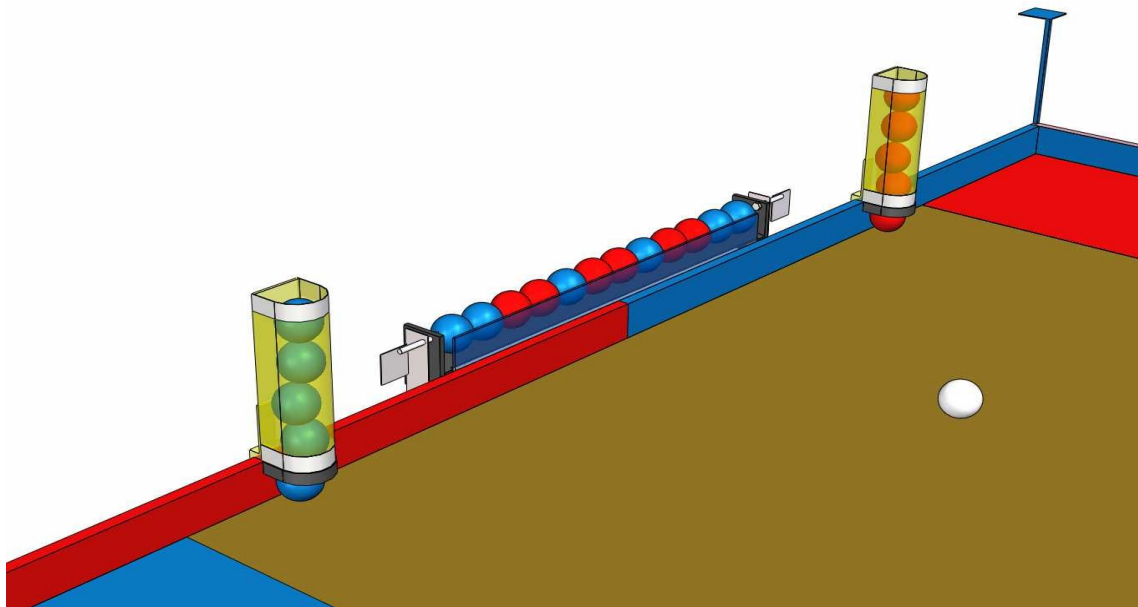
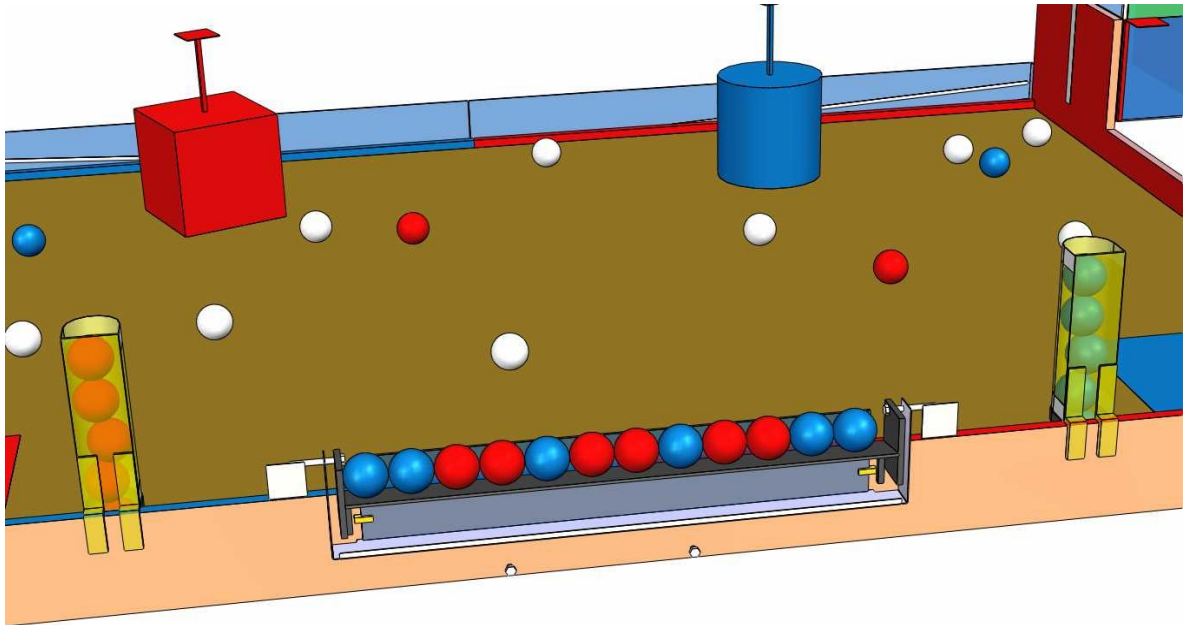



---

Rules 2008

---

3.6.3. Samples and ice distribution on the table

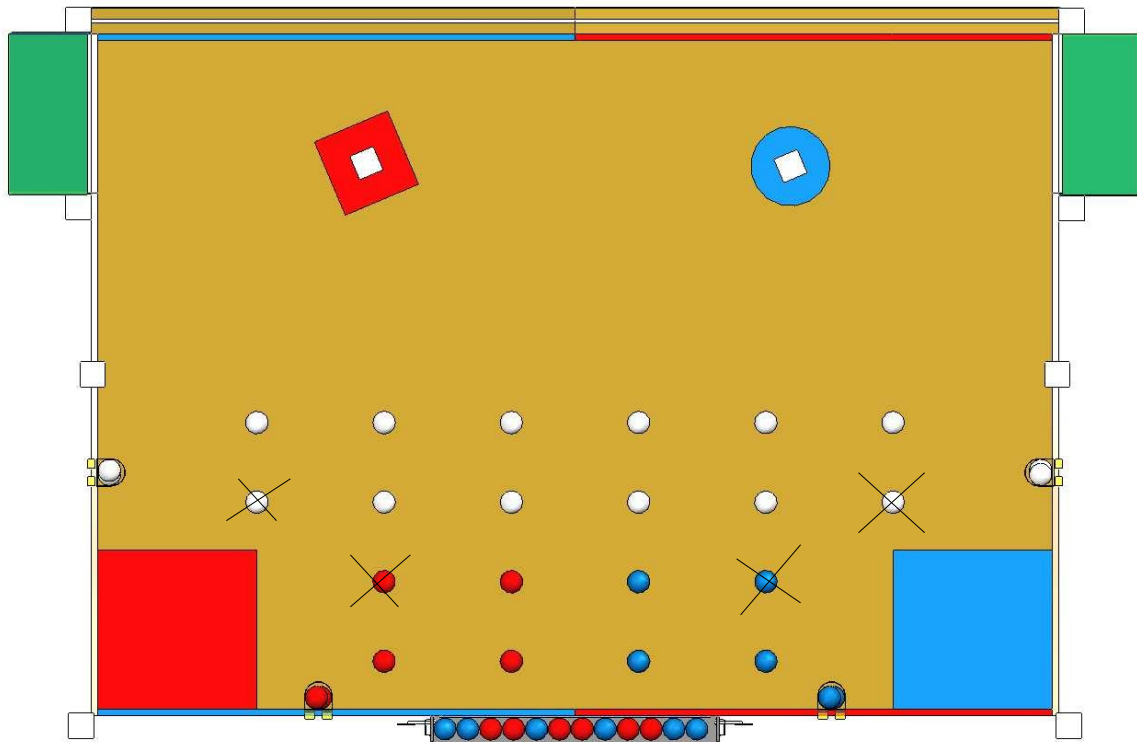

There are 20 rock/soil sample and ice placement positions on the table, as indicated in the diagram : 4 pre-defined positions and 16 random positions. The fixed positions are indicated as black crosses, with the colour of the ball which will be place there. The other positions are random. Before the match, a randomly drawn card is used by referees to determine the colours of the balls that will be placed on these random positions.

---

## Rules 2008

---

### 3.7. The containers

---

#### 3.7.1. The standard container

This container is figured by a sloped ditch, placed outside the robot evolution area, along the front edge facing the audience. It is composed of two slopes. At the table corners, the bottom of the standard container is level with the table surface, sloping downward from there. At the slopes junction point, half-way from both ends, the bottom is **80 mm** below table level. The slopes are painted in grey yellowish, like the rest of the table. Slipping (TEFLON type) scotch is stuck on each side of the slopes

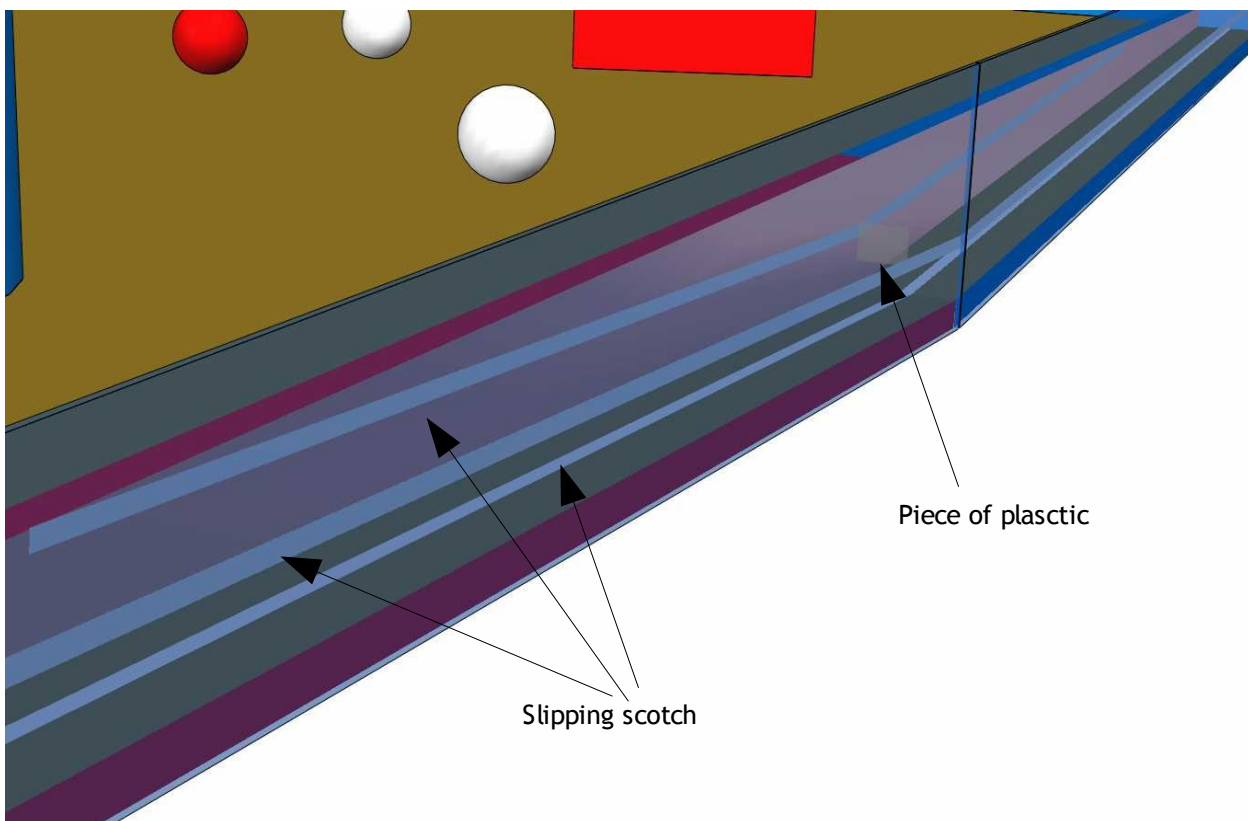

where the balls rolls, to facilitate rolling and avoid jam.

A small rectangular piece of semi-rigid plastic, measuring **40 x 30 mm**, is attached vertically on the interior border, at the junction of the two slopes. The piece of plastic is transparent. It separates the red and blue parts of the container. This piece stops balls rolling down the slopes, so that they don't enter by themselves in the other camp, but being supple, it let them go on the other side when pushed by a robot. This piece of plastic delimits the two areas (red and blue) and in which area the balls are.





Eurobot<sup>open</sup> 2008

Mission to Mars



---

## Rules 2008

---

The exterior side of the standard container is closed by a plexiglass plate, so that the audience can see the collected samples and ice blocks. The top part of this plexiglass plate is located **80 mm** above the table level all along the container.

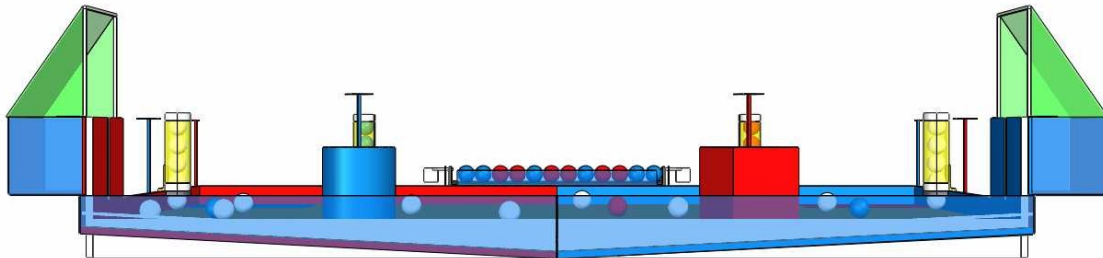

### 3.7.2. The cooled containers (safe zones)

The cooled containers are located at the front end of the short sides of the table. They are represented by baskets of which the opening is from **350 mm to 700 mm** in height from the table level. The back part, the receptacle, is **500 mm long, 250 mm wide and 180 mm high**. The green part on the drawing hereafter is made of net, mounted tightly.

A vertical reflective tape is placed at mid-width of the basket opening, extending from 75 mm above the table level, up to to opening.





---

## Rules 2008

---

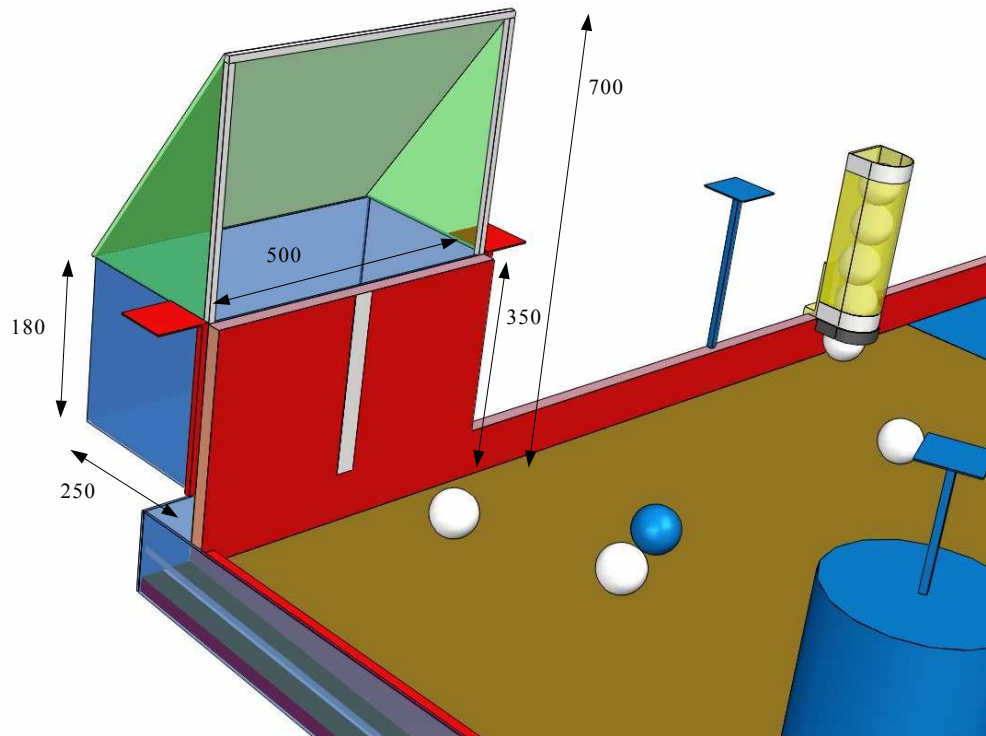

Each team has its own cooled container (located opposite to the robot's starting area) reserved only for the correct rock and soil samples. All other material results to reduction of score.

## 4. The robots

### 4.1. General notes

---

Only one robot per team is allowed to participate to a match

The robot is a fully autonomous machine. It shall carry its own power source, actuators and control system.

The robot is only allowed to communicate with the localisation beacons (see beacons, below).

During matches, no remote controlled action is allowed: the robot runs strictly on its own.



---

## Rules 2008

---

### 4.1.1. Visibility

The refereeing committee encourages the team to make the interior parts of their robot visible.

Two areas of 100 mm x 70 mm must be available on the robot for the placement of stickers (number of the team and logos of the sponsors of the event, printed by the organizer). The stickers could be placed on two different sides of the robot.

## 4.2. Limitations and safety issues

---

### 4.2.1. Carrying or throwing the balls

The robots are allowed to carry **5 balls at most**.

This means that at most 5 balls can be taken on board or controlled by the robot's devices or structural elements (such as a fork or a bulldozer like blade) at any time. A ball is considered as controlled by the robot if the robot directly and intentionally influences its trajectory and moves. If the robot needs to take up another ball with five already inside it, it must first release one of the five it is carrying, and then take the new ball.

The robots are allowed to throw balls. But they are not allowed to throw or put the balls off the table, or to throw at the opponent robot.

### 4.2.2. Usage of blowers or vacuum systems

Usage of blowers is not allowed to move balls on the ground or to remove balls from the scoring areas. They can only be used to throw balls in ballistic systems.

Usage of vacuum systems is allowed to pick up and carry balls.

### 4.2.3. Fair-play

The aim is to share a friendly time and play as many matches as possible. Therefore, any action not directly in line with the match spirit as laid out in this document or harmful for match development will be penalised. The goal of the match is not to prevent the other robot from playing.

In this spirit, teams shall not make use of strategies that may for example lead to:

- the robot blocking the opponent robot's access to an element or area of the playing field
- deliberately designing the robot (colouring, shape) in order to confuse the opponent robot. None of the colours mentioned in these rules for playing field elements or playing accessories (balls,...) can be used on the robot.



---

## Rules 2008

---

- the robot causing intentional damage to the opponent robot, the playing area, or any of the playing field elements.
- using fixture systems (fi. suction cups). At any time during the match, the effort required to lift the robot must not exceed its own weight
- keeping the balls of the opponent team or hiding the balls of the opponent team in own cooled container. More generally, preventing the opponent robot from accessing its own playing elements.

### 4.2.4.Safety

The robots should not have any protruding or sharp parts that may be able to inflict damage or that can be dangerous.

The use of liquid products, corrosive products, pyrotechnic materials or living beings in the robot is forbidden.

All the systems on the robots shall respect existing national and European laws and specifications. Specifically, the systems used shall comply with legal safety regulations and must not endanger the participants or the public both during matches and backstage.

As a general rule, any device or system considered as potentially dangerous by the referee will be rejected, and must be removed from the robot prior to competition, or result in disqualification.

These points will be checked during the approval phase of the competition, before the robot will be allowed to participate to matches.

## 4.3.Mandatory equipment

---

All robots must include the following systems, or they will not be approved for competition.

### 4.3.1.Starting cord

This starting device shall be easily accessible on the robot. It shall be triggered by pulling a cord at **least 500 mm** long. This cord shall not remain attached to the robot after this one has been started. Any other system (remote control, toggle switch directly activated by hand, etc...) will not be approved.

### 4.3.2.Emergency OFF button

The robot must include an emergency off button, with a diameter of **at least 20 mm** painted in red (for example a safety emergency stop button). It shall be placed on the top of the robot, in a conspicuous position and in a zone that is not dangerous and that is immediately accessible to the



Eurobot<sup>open</sup> 2008

Mission to Mars



---

## Rules 2008

---

referee at any time during the match. The stop button must be actuated by a simple downwards motion (such as a hit with the fist).

Pressing the emergency button must result in the immediate shut down of all of the robot's actuators, leaving them limp (not actively braked nor energized).

### 4.3.3. Automatic shut down

Each robot shall accommodate a system which shall stop the robot automatically at the end of the 90 second match duration. "Stop" implies complete shut down of all actuation including internal devices. Robots moving after the end of the match will be penalized or disqualified.

### 4.3.4. Obstacle avoidance system

Teams are required to equip their robots with an obstacle avoidance system. The system is intended to prevent collisions and damages between robots during a match.

The robot must be able to avoid at least an obstacle modelled by a cylinder 300 mm high having 200 mm in diameter and weighting between 2 kg and 3 kg. This fake robot will have a beacon support, in case the team makes use of a beacon-based opponent localisation system.

## 4.4. Robot Dimensions

---

Robot can have deployable extensions, but their deployment is allowed after the match start signal only.

The perimeter of the robots is defined as the convex envelope which fits the vertical projection of the robot on the ground.

The perimeter of the robot in its starting configuration shall not exceed **1200 mm**.

The perimeter of the robot in a fully deployed configuration shall not exceed **1400 mm** at any time during the match.

The perimeter of balls controlled by the robot during the game is not limited by these dimensions.

The height of the robot shall not exceed **350 mm**, excluding the beacon supporting mast, possible sensor equipment within the beacon support mast's envelope and possibly the pressing part of the emergency stop button. Teams are warned that if some tolerance is left with respect to the maximum height for the emergency stop button, this one must not represent any form of annoyance for opponent beacon systems. In case of protest, the team will be penalized, and it will be asked to modify the robot accordingly, before this one will be re-allowed to participate to the competition.

The robots do not have dimensions constraints with respect to deployment under the table level.

All other systems, including mandatory systems, must be contained within the volume specified above.

Rules 2008

All parts of the robot must remain physically connected - therefore the robot cannot leave parts of itself on the playing area

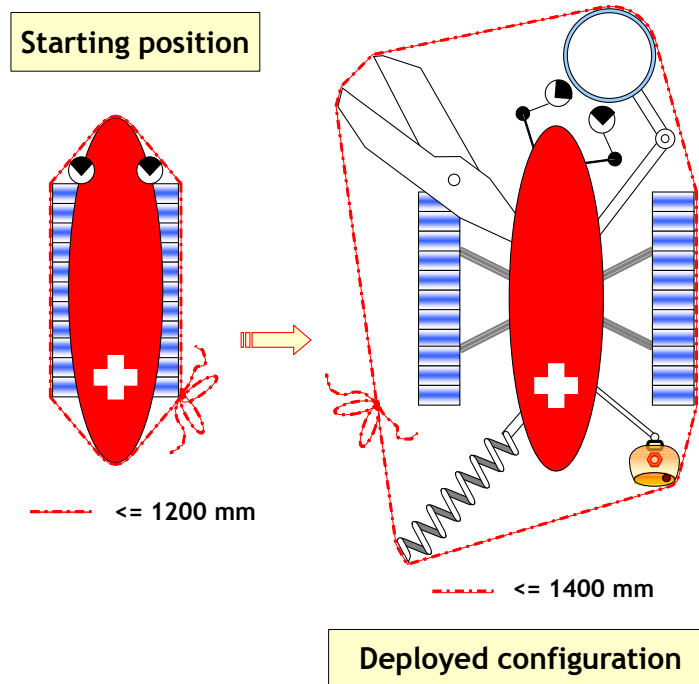

*Important notice* : Since it has been observed that every year some robots are slightly above the allowed dimensions because designed too close to the limits, teams are strongly advised to keep some “safety margin”, and stay several millimetres under the above mentioned limits, so that no “bad surprise” will happen at approval time.

## 4.5. Energy Sources

Allowed energy sources include springs, pressurised gas, solar cells (note that the competition will be held indoors) and most types of commercially available batteries and power cells,

Prohibited energy sources include all types of combustion engines, rocket engines, hydrogen fuel cells, or any other type of burning or pyrotechnics, living beings and radioactive energy sources of all types.

If in doubt about your unusual energy source, ask the refereeing committee ahead of time.

With respect to batteries use only models with solid electrolyte in order to prevent any problems with corrosive liquids



---

## Rules 2008

---

It is strongly recommended for teams to possess several battery sets and to design for easy access in the robot for their replacement. The teams are reminded to have spare, fully-charged batteries available at all times.

Teams are required to be capable of playing two matches in succession. Note that this includes the necessary “setup time”, when the robot is powered on and waiting to start, but the match has not yet begun.

### 4.6. Control Systems

---

The teams may use any kind of robot control system (analogue, microprocessors, micro-controllers, computers, programmable logic, etc.).

Those systems must be fully integrated into the robot.

The control system must permit the robot to play a match as either colour.

The control system must permit the robot to pass the approval phase.

### 4.7. Robot localisation beacon support

---

It is strongly recommended to design the robot with a support to accommodate a localisation beacon prepared by the opponent team.

If desired, the support can be designed to be detachable, so that it is only used if the opponent needs it. In this case the design must allow the support to be quickly attached before the match.

Finally, a team may choose not to include a beacon support. In this case, if the opponent provides a beacon and wants to use it during the match, the team will be disqualified for not having the support.

The beacon support shall at all times comply with the following constraints:

- It is a **80x80 mm** square surface, located **430 mm above the floor level**. The structure supporting this platform must stay within the vertical projection of this platform. This mast cannot host any parts of the robot other than sensors. The mast shall be robust and rigid enough to support the opponent’s beacon in a stable fashion. The team is responsible for the robustness of its mast.
- The platform surface of the support shall be fully covered with Velcro (rough “hook” side)
- The support shall be located close to the horizontal centre of the robot. In robot non deployed configuration, the distance between the support and the maximum robot extension on one side shall not be less than 50% of the equivalent distance on the opposite side.



Eurobot<sup>open</sup> 2008

Mission to Mars



---

## Rules 2008

---

### 4.8. Technical poster

---

Each team is required to provide a technical poster during the approval phase.

This poster should present information related to the design of the robot (drawings, technical references, design specifications, etc...). It should be at least DIN A1 in size, and ideally should be printed. The poster is intended to promote exchange and communication between teams.

Effort should be made to make the poster understandable to a non-technical audience. Ideally the poster should include pictures and diagrams to help explain the concepts.

The poster must also include:

- the name of the team
- the names of the team members
- the nationality of the team

This poster will be displayed in the team's pit. An English version of the poster must be supplied. Optionally, the team can provide other language versions as well.

The poster shall be supplied to the Eurobot association in PDF Format. The chosen resolution of the PDF must guarantee that all texts on the poster will remain readable. The file size of the PDF should remain below 25MB.

The PDF Version of the poster may be sent to Eurobot beforehand via your National Organisation Committee, or may be provided on CD-ROM or USB key at the competition, during the approval for your robot.

In general, Eurobot incite the teams to communicate around their projects, on Internet, the forum, etc.

## 5. Beacons

### 5.1. General Comments

---

Beacons are not allowed to obstruct the opposing robot. If there is any doubt that they may deliberately disturb the development of the match, the team will not be allowed to use them.

Four fixed beacon supports are placed on each short side of the playing area: one at the back corner, one at the centre and two others on each side of the cooled container. They are black and placed at a height of **350 mm** above table level.



---

## Rules 2008

---

The beacons' undersides are covered with Velcro (soft "loop" side ) as a way to fasten them on their assigned support.

The beacons (robot localisation or fixed ones) shall remain on their support throughout the matches.

The use of beacons is optional.

All safety standards applicable to robots are also applicable to the beacons.

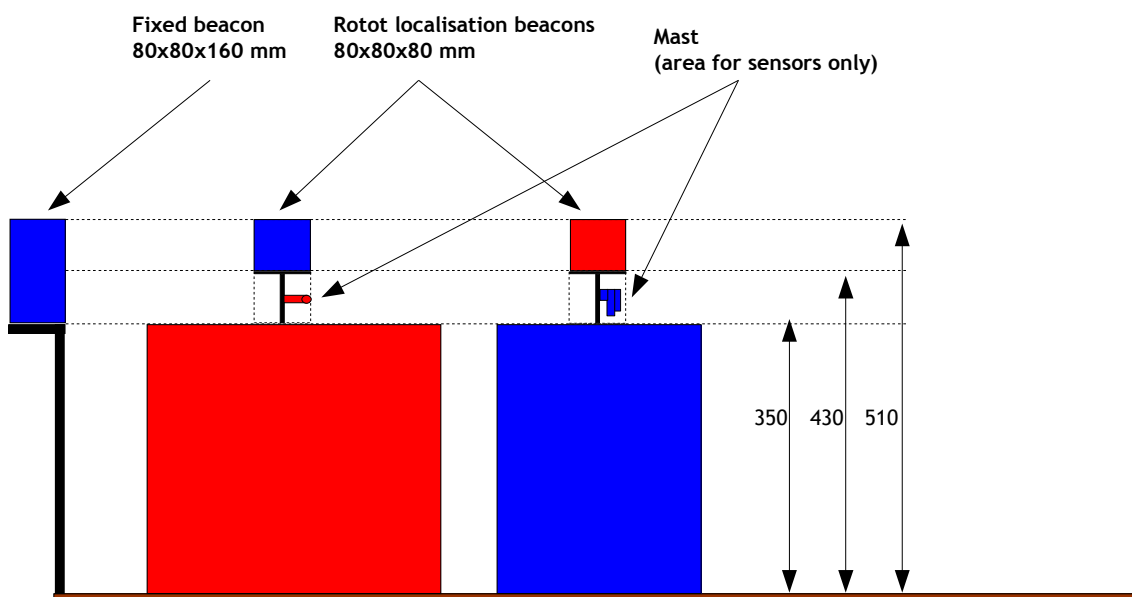

All dimensions are in millimeters

## 5.2. Robot Localisation Beacon

---

One localisation beacon can be fitted onto the other robot, in order to locate it. This beacon will be fitted on the beacon support provided for this purpose by the opponent robot.

Only one localisation beacon is allowed per team.

The maximum size for a robot localisation beacon is an **80 mm edge cube**.

The elements used for the beacon design shall be useful. The referee may request if necessary that the team opens its beacon casing for inspection and verification.

The robot localisation beacon top shall be covered with Velcro (rough "hook" side) able to support the flag module identifying the robot allocated colour.





---

## Rules 2008

---

### 5.3. Fixed beacons

---

Each team can use a maximum of three beacons, to be placed on the provided supports around the playing area.

All three beacons can be linked together by a wire. This optional wire must not disturb the development of the match and the team must be able to install it during the 3 minutes for match preparation without disturbing the opponent team.

The beacons must remain within a square base of **80x80 mm** and can be up to **160 mm high**.

### 5.4. Communication signals

---

In order to avoid interference between the teams, it is recommended to encode the communication signals. We strongly recommend that teams using infra-red devices take into account the strong ambient light used during the competition. Moreover, this illumination may vary over time and location during the competition.

We also mention that the competition staff uses high frequency radio devices during the contest.

No complaint regarding interference problems will be taken into account. The beacons must be able to cope with the conditions that may change depending on the moment and their location during the contest.

## 6. Match time line

### 6.1. Robot identification

---

For each match, the robots are allocated a colour marking built as a small flag module: red or blue. The use of this marking is to help the public to associate at any instant a robot with its team.

The flag module mass is negligible. It is placed directly on the robot beacon support, or directly on the robot. If the robot does not provide a beacon support, it must provide a **80x80mm square** surface covered with Velcro (rough “hook” side) at the top of the robot to place the flag marker on.

### 6.2. Start procedure

---

- A colour (red or blue) and therefore a side of the playing area are allocated to the team before each match.



---

## Rules 2008

---

- Only two members from each team are allowed to access to the stage area for robot preparation.
- Both teams have **3 minutes** to put their robot on the starting position, to prepare it and to install all beacons.
- The robots are placed on the table, entirely within their starting areas, and **touching the two table borders** adjacent to the starting area.
- After the 3 minutes preparation time, no more intervention or transmission of external information to it is allowed.
- When both teams and the referees indicate they are ready, the referee will determine the random positions for the balls to be placed on the table. This is done by drawing from a set of cards. Each card indicates a different placement of the elements. These cards are available as a PDF file on the Eurobot website. During this procedure, the teams are not allowed to touch their robot nor communicate with it.
- The referee asks the participants if they have any remark about the placement of all the game elements. No objection regarding the placement will be accepted after this point.
- At the start signal given by the referee, the robot is activated by one of the team members. The robot shall then run on its own in a fully autonomous way.

Any team which does not scrupulously follow this starting procedure (anticipated or delayed start) is charged with a false start. A new start shall be given with a new random layout for the game elements.

### 6.3.Match sequence

---

Robots have **90 seconds** to score as many points as possible. This must be accomplished in complete autonomy.

The team members are not allowed, in any way, to touch the robots, the playing area or any of the fixed game elements during a match. Any action made without the referees consent will lead to disqualification for the current match. The team will then lose all the points it may have scored during the match.

If the robot leaves the playing area, it can't be put back in. The match is not replayed and the other robot is allowed to finish the match normally.

A robot that deliberately pushes its opponent out of the playing area is disqualified.

At the end of the match the robots must stop (shut down of all actuation) by themselves. If the robot does not shut down by itself, a referee will push the emergency stop button to stop the robot.

The referees will count the points without touching the robots. Then they will announce the score.



Eurobot<sup>open</sup> 2008

Mission to Mars



---

## Rules 2008

---

The team members are allowed to touch the robots and leave the game only with the explicit consent of the referees after common agreement on the score. They must ensure that no playing element has been kept inside the robot.

### 6.4. Score calculation

---

#### 6.4.1. Points

Points are counted after the match is over.

After the match, the samples and ice blocks in the containers are counted as follows :

For collecting ice into correct part of the standard container:

- 1 ice ball in **red part** of standard container = 1 point for **red robot**
- 1 ice ball in **blue part** of standard container = 1 point for **blue robot**

For collecting the correct type of rock and soil samples :

- 1 **red sample** anywhere in the standard container = 2 points for **red robot**
- 1 **red sample** in the **red cooled container** = 2 points for **red robot**
- 1 **blue sample** anywhere in the standard container = 2 points for **blue robot**
- 1 **blue sample** in the **blue cooled container** = 2 points for **blue robot**
- incorrect material (opponent's sample or ice) in the cooled container = -1 point

#### 6.4.2. Bonus points

To reward samples preserved in the best conditions in the standard container, samples which will be placed between two ice balls will score a bonus of **3 points** to the respective robot (i.e. red sample to the red one and blue sample to the blue one).

#### 6.4.3. Scratch

The team is scratched when :

- it does not come on time to the backstage waiting room for matches;
- it takes more than 3 minutes to get ready on the playing area;
- its robot has not completely left its start area during a match;



---

## Rules 2008

---

- its robot doesn't have a mobile beacon support, when its opponent requests and requires one.

### 6.4.4. Penalties

A penalty results in the removal of points from the score of the team at the end of the match. Any actions not compatible with the spirit of the rules may be penalized by the referees. For example, the referees may assign penalties in the following cases:

- When a robot violently collides with its opponent
- When a robot is considered dangerous for the table, the audience or its opponent
- When a robot deliberately prevents its opponent to access a game element
- If a robot's shut-down system fails to work
- If a robot intentionally or systematically throws balls outside of the table
- If a robot keeps the balls of the opponent's team
- If the robot puts the balls of the opponent's team in its own cooled container
- Whose robot shows a deployment or an action that has not been previously approved by the referees, or any deliberate action not in line with the rules.

Additional penalties can be applied if the referees consider this justified. For instance, if a team has been warned about some negative point during a match, and the same point is noticed during a subsequent match, this will turn into a penalty. The scoring system used for the competition sports a feature to record such warnings, so that the referees can know about past events for this team and take them in account accordingly.

It must be noted that **negatives scores are possible** if penalties exceed the number of points scored during the match.

### 6.4.5. Match point

A preliminary total of the point is calculated with the points scored by the balls and with the penalties. Match points will then be added to these points, based on the following rules :

- 4 points for a victory
- 2 points for a draw
- 1 point for a defeat
- 0 point for a scratch



---

## Rules 2008

---

A score of 0/0 is considered as a double defeat. Thus, each team gets only 1 match point.

### 6.4.6. Disqualification

The referees may disqualify a team for the competition:

- When the robot makes the same penalized actions systematically
- For the unacceptable comportment of the team

## 7. Contest master time-line

### 7.1. Approval

---

A robot must be approved before being allowed to participate in the tournament. For logistical reasons, and reasons of fairness, there is a deadline for approval. All teams must approve their robots before this deadline. Robots that are not approved will not be allowed to participate in the tournament.

#### 7.1.1. Physical examination and team interview

The referee examines the robot and interviews the team to check the following:

- That the robot complies with the rules (the robot should be capable of demonstrating all of its possible actions and deployment configurations to help verification).
- That the team provides a technical file of the system use by the robot (lasers,...)
- That the team provides a technical poster
- That the team understands the rules and the spirit of the tournament
- That the emergency stop button works, and all actuators are shut down when it is pressed

#### 7.1.2. Practical trials

In addition, the robot must pass two tests:

1. That under match conditions, without opponent:
  - The robot is capable of leaving the start area



---

## Rules 2008

---

- The robot is able to score (obtain at least one point, without an opponent) within the limit of 90 seconds
  - The robot's shut down system works properly
2. The robot's obstacle avoidance system works.

The system should be able to successfully avoid a static dummy obstacle (fake robot made of a 300 mm high and 200 mm diameter cylinder, weighting between 2kg and 3kg) placed at a random distance in front of the robot on the table. This fake robot sports a beacon platform , so that it is possible to place a beacon on it.

### 7.1.3.Modifications after approvals

It is mandatory to keep referees informed of any major modifications (functionality, size, etc.) made after approval. The referees will check the modifications and re-approve the robot.

Actions used during the match which were not demonstrated during the approval process can lead to penalties or disqualification.

Referees can require a robot to subject itself to another approval process at any time during the competition, if in doubt about its conformance to the rules.

## 7.2.Qualification round

---

The format of the national competitions may differ from the mode described below. Eurobot encourages the national organizing committees to plan their national tournaments to allow the teams to play many matches. The more matches, the more fun, and the clearer the results.

The Eurobot organization will try to organize at least five matches for each team during the qualification round. The results of the qualification rounds decide which teams go to to the final round.

When the qualification rounds are over, the teams are sorted using their qualification points count. The teams that have the same points count are sorted by comparing the points accumulated during each match without adding the bonus points for match result.

In case of equalities, the organisers may request extra matches. Pairs of teams competing for the same rank will be randomly drawn, and resulting matches will be played on a knock-out basis. In case of odd number of teams, an additional random match will be played, on the same basis.

## 7.3.Final round

---

At Eurobot, the first 16 teams from the qualifying phase are selected for the final round. In a national competition the final round may be smaller, depending on the number of registered teams.



## Mission to Mars

---

### Rules 2008

---

During the final phase, matches are on a knock-out basis. The matches for the final round are organised as shown in the diagram below.

In the event of a double defeat, a draw or a double disqualification the match is replayed immediately. If this second match is also a double defeat, a draw or a double disqualification, the winner will be determined by the position at the end of the qualification rounds.

The final match is played until two winning sets.

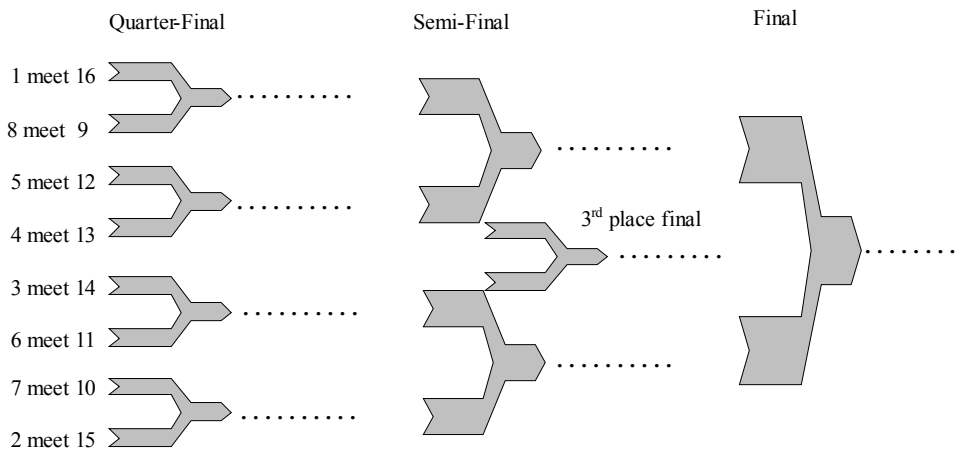



Rules 2008

## 8. Appendices

### 8.1. Playing area drawing

Dimensions are given in mm and are subject to the general tolerances defined.

Top View

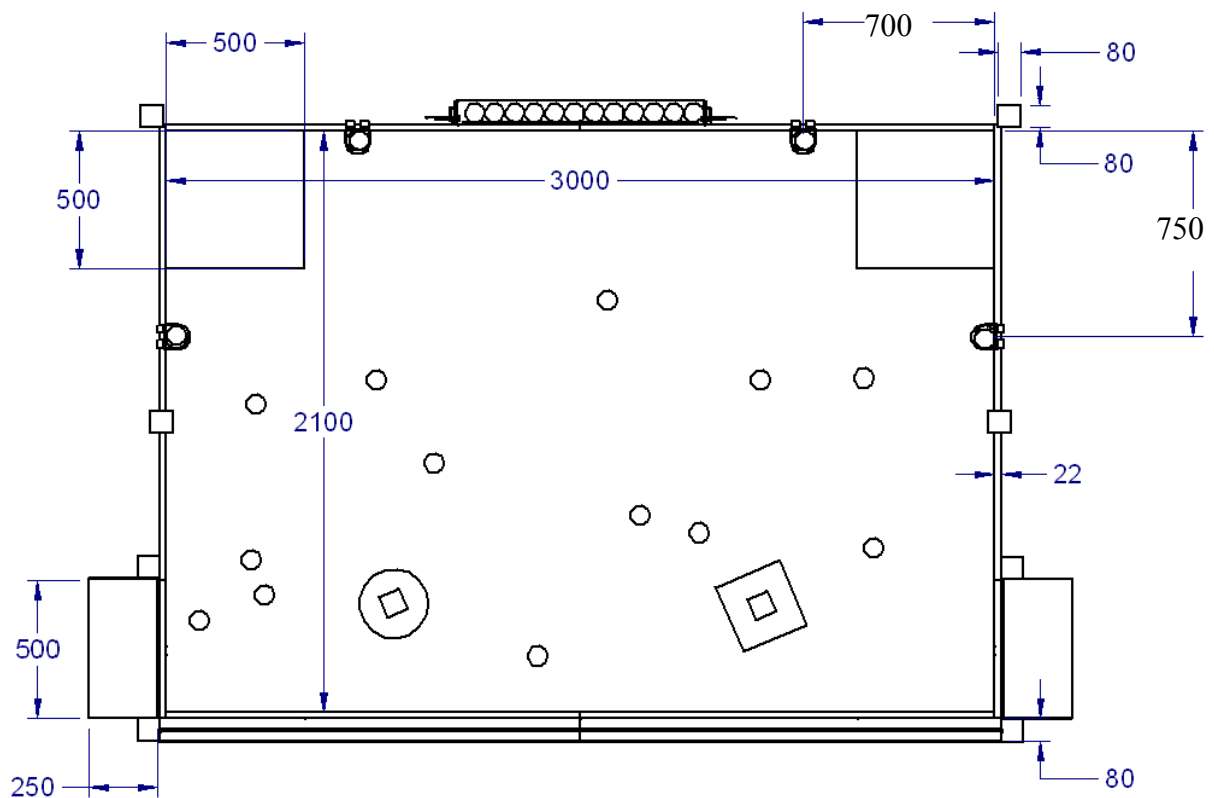





Eurobot<sup>open</sup> 2008

Mission to Mars



---

Rules 2008

---

Face view

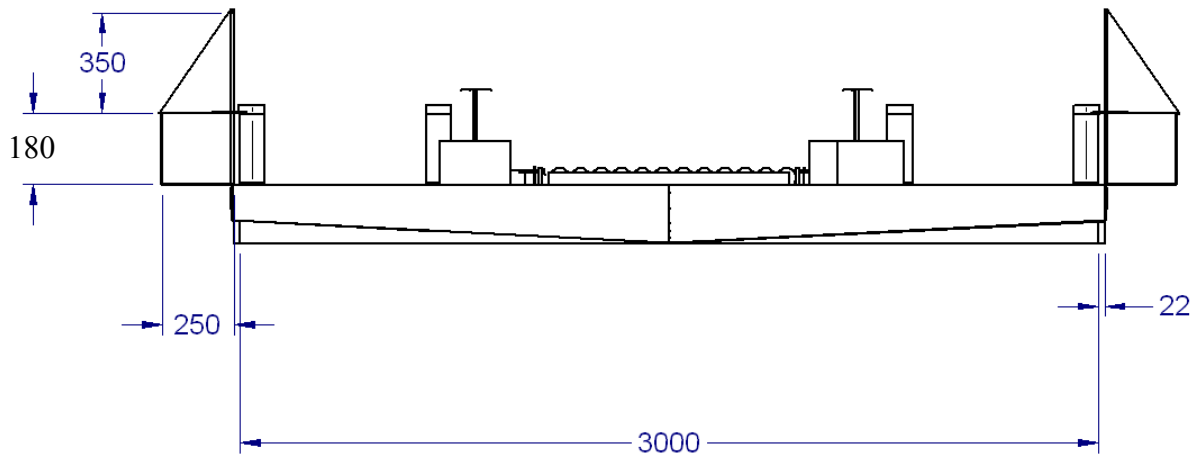

Face view (goal area)

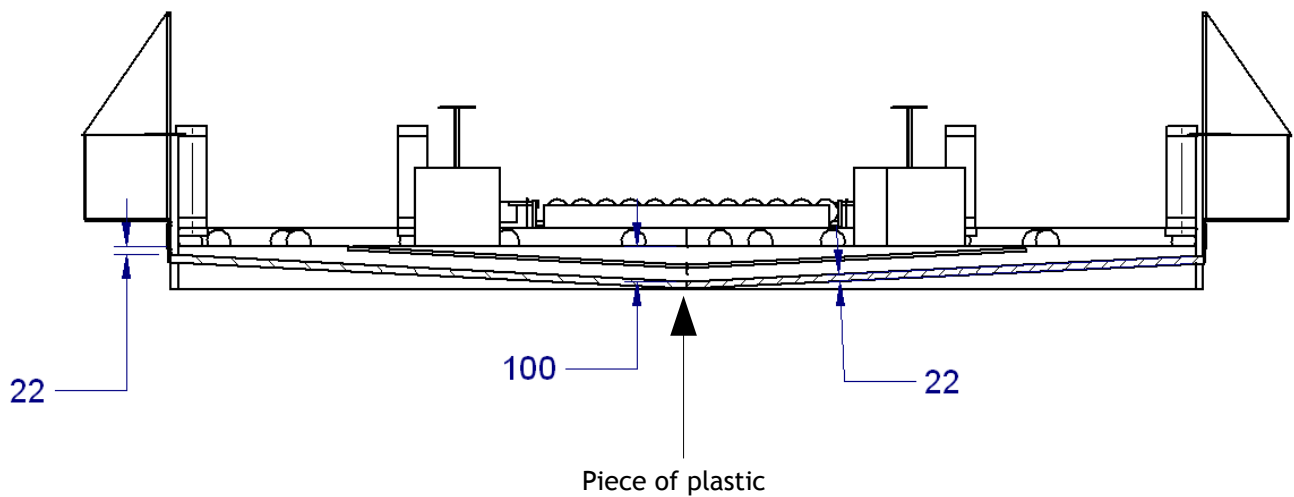

---

Rules 2008

---

Back view

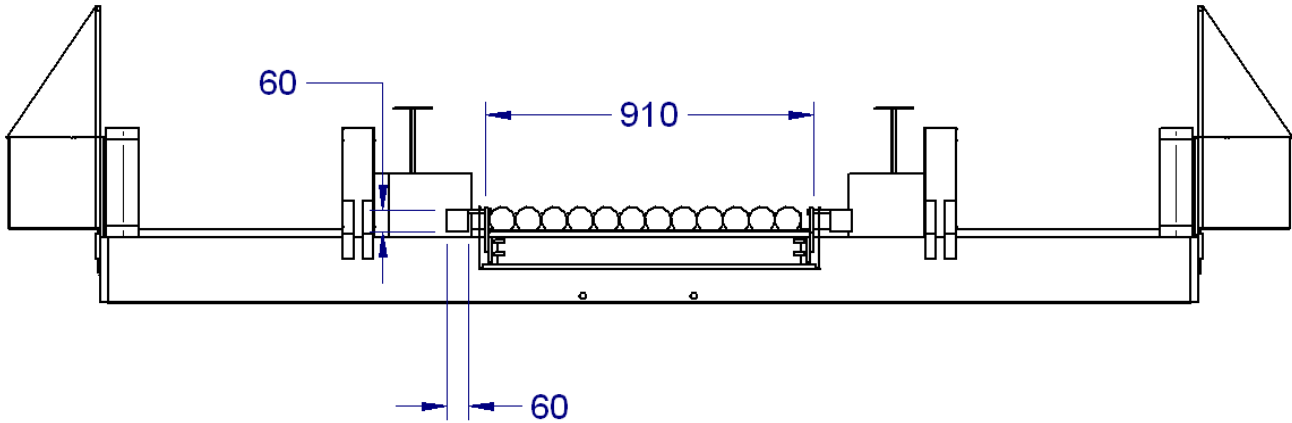

Side view

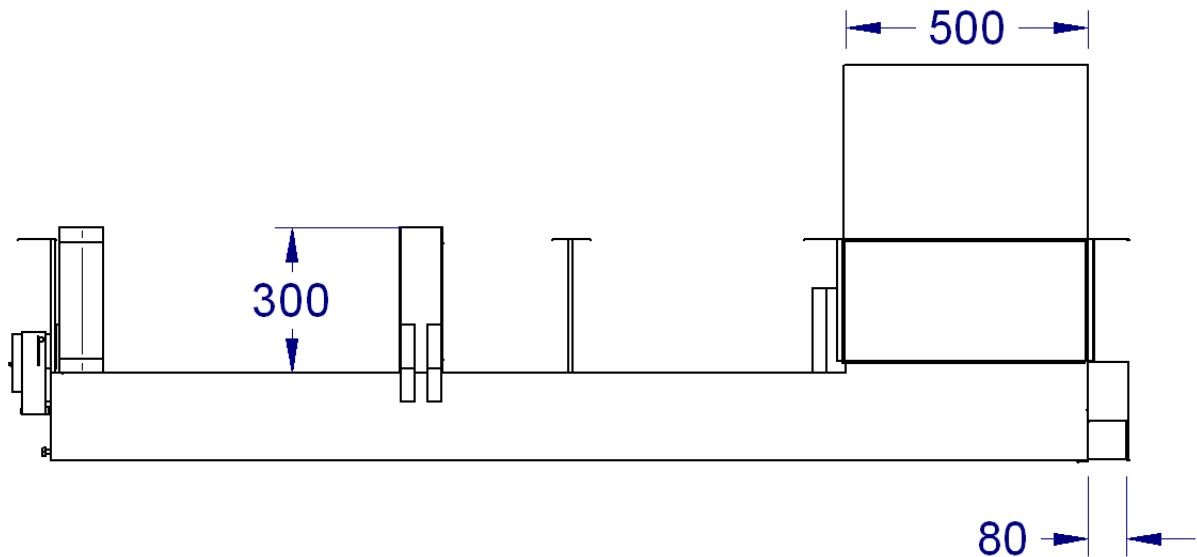

## 8.2. Reflective tape

---

This is made of an adhesive retro-reflector tape 0,2 mm thick and 25mm wide, white in colour. To know a reflective tape provider, please contact your National Organization Committee or Eurobot Association for the independent teams : [referee@eurobot.org](mailto:referee@eurobot.org) .



---

## Rules 2008

---

### 8.3. Painting references

Element	Colour	Paint Type	Reference
Playing field	Grey Yellowish	Acrylic, mat	RAL 7034
Blue start area, blue border	Blue (signalisation)	Acrylic, mat	RAL 5005
Red start area, red border	Red (traffic)	Acrylic, mat	RAL 3020

### 8.4. Balls specifications

---

The ball diameter measures **72 mm**. The hole diameter is **10 mm**. The approximative weight of the balls is **23 grams**.

To know the balls provider, please contact your National Organization Committee or Eurobot Association for the independent teams : [referee@eurobot.org](mailto:referee@eurobot.org) .





---

## Rules 2008

---

### 8.5. Safety

---

Hereafter are listed some safety regulations. This list is not exhaustive - the referees' decisions are final on what is dangerous, and what is not.

One of the design goals for your robot should be to develop systems that are safe for people, both during the competition and during the construction and experimentation phase of your project. This is also why you must ensure that your systems comply with applicable regulations for technical devices.

#### 8.5.1. On-board voltage

All robots must comply with the legal standards concerning "low voltage". Therefore, the internal voltage of the robots **shall not exceed 48 V**.

Internal voltage must be understood as the potential of any part of the robot in direct access with or without its casing in place. Direct access includes access to parts insulated by the teams themselves, using adhesive tape, thermo shrinking tubing, or any similar non industrial process.

It is allowed that potentials higher than 48V exist, but only inside closed devices such as lasers, LCD display back lighting,.... and only if these devices have been left unmodified.

Any element of the robot not complying these rules will have to be removed for the robot having a chance to be approved.

#### 8.5.2. Compressed-air systems

All pressure systems must comply with applicable laws. In France this shall be in accordance with the "Conseil Général des Mines" (French safety and approval board).

Decree 63 of January 18, 1943 and Ministerial Order of July 25, 1943 (French legislation):

- Maximum pressure: **4 Bars**
- Maximum Pressure x Tank Volume product: **80 bar.liter**

Further information may be found on <http://www.industrie.gouv.fr/sdsi/> (for France).

#### 8.5.3. Lasers

Only considerations based on laser classes will be taken in account from now on, and teams using a laser will have to provide the classification notice of the equipment, or the data sheet of the laser component. Not being able to provide such documents will prevent the robot to be approved as is.

Based on the official classification, lasers are classified as follows :

- **class 1** : lasers will be accepted without condition.



Eurobot<sup>open</sup> 2008

Mission to Mars



---

## Rules 2008

---

- **class 2** : lasers will be accepted if, and only if,
  - if the laser is installed on a rotating turret with the speed not lower than 1 revolution per minute. Without rotation, the laser must be shut down.
  - the path of the laser spot will never cross eye position, intentionally or not, be it for people around the tables or in the tribunes.
- **all other classes (3A, 3B and 4) are strictly forbidden.**

Teams not complying to these rules (by providing incorrect documentation for instance) will be held responsible in front of the justice in case of any damage resulting from their system.

### 8.5.4. Powerful light

When high intensity source are used, be aware that the light intensity can be dangerous for the human eye in case of direct illumination. Note that some high power LED devices can exceed this limit.